

Installation instructions

for NoFrost combined refrigerator-freezers

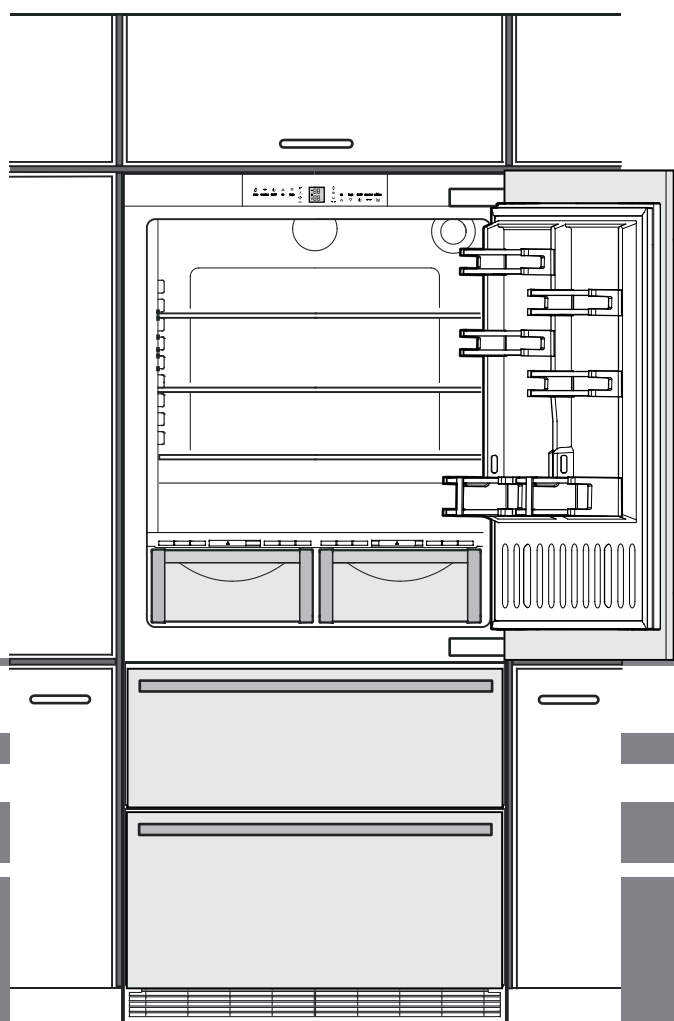

7082 725-00

ECN / ECBN 61

LIEBHERR

Mounting the anti-tipping device



WARNING!

The supplied anti-tipping bracket must be installed in all cases. This prevents the appliance from tipping over when the fully loaded door is opened.

Installation:

1. Mark the centre line of the appliance on the floor.
Align the anti-tipping bracket centre to the centre line.



CAUTION!

Ensure that there are no electric cables or water pipes in the wall section to which the anti-tipping bracket is to be secured. These could be damaged during installation.

2. Secure the anti-tipping bracket to the floor using the 3 screws (6 mm x 60 mm) included in the accessory pack.
The distance between the leading edge of the body of the unit and the rear edge of the anti-tipping bracket is 610 mm.

Important!

When securing the anti-tipping bracket to a concrete floor, use suitable plugs!

If the floor slopes down sideways, the anti-tipping bracket must be fitted horizontally. Lay down spacers in the appropriate positions.

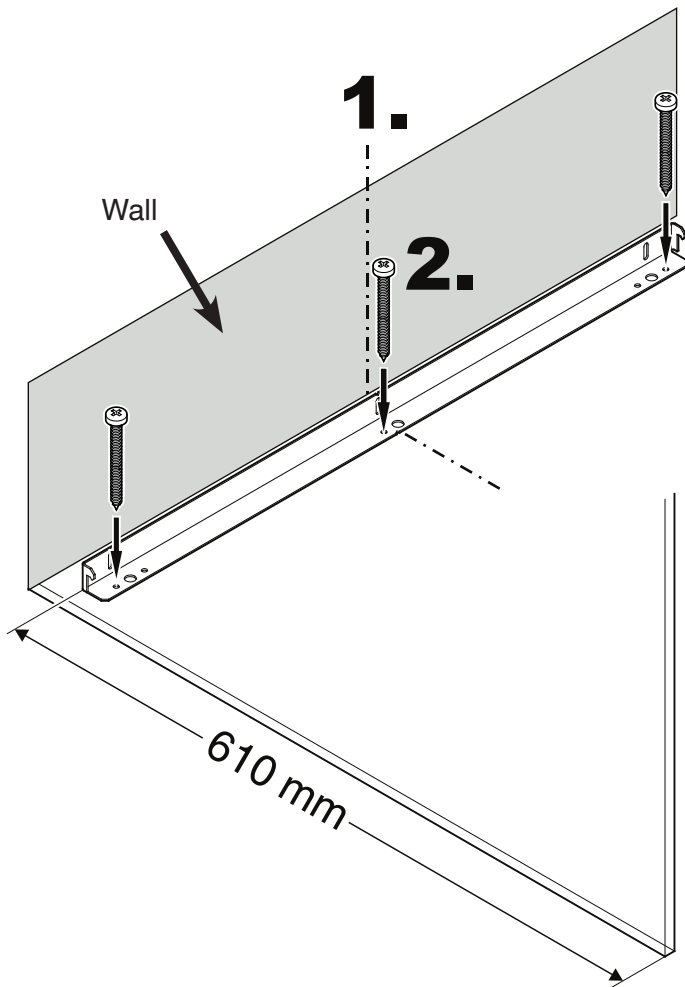

Connection to the water supply

Safety instructions and warnings

- Do not connect to the water supply while the combined refrigerator-freezer is connected to the electricity supply.
- The connection to the mains water supply may only be made by trained personnel.
- The water quality must comply with the drinking water directives of the country in which the appliance is used.
- The ice maker is designed exclusively to make ice cubes in quantities required by a household and may only be operated with water suitable for this purpose.
- All repairs and work on the ice maker may only be carried out by customer service personnel or other trained personnel.
- The manufacturer cannot accept liability for damage caused by a faulty connection to the mains water supply.

Water pressure

The water pressure must be between 0.15 and 0.6 MPa (1.5 - 6 bar).

Important:

If the water filter is inserted in the appliance, the water pressure must lie between 0.3 and 0.6 MPa (3 - 6 bar). If the water pressure with the inserted water filter is too low, this may cause the ice maker to malfunction.

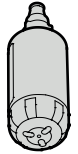

The water supply to the appliance must be through a cold water pipe that can withstand the operating pressure and complies with the hygiene regulations. For this, use the stainless steel hose supplied (length 3 m).

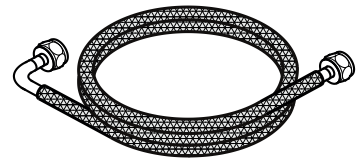

Installation

1. Place the appliance in front of the installation recess.

2. Apply cover strips above, between and below the securing plates on the side walls of the appliance.

Cut the cover strips to the right length for this purpose.

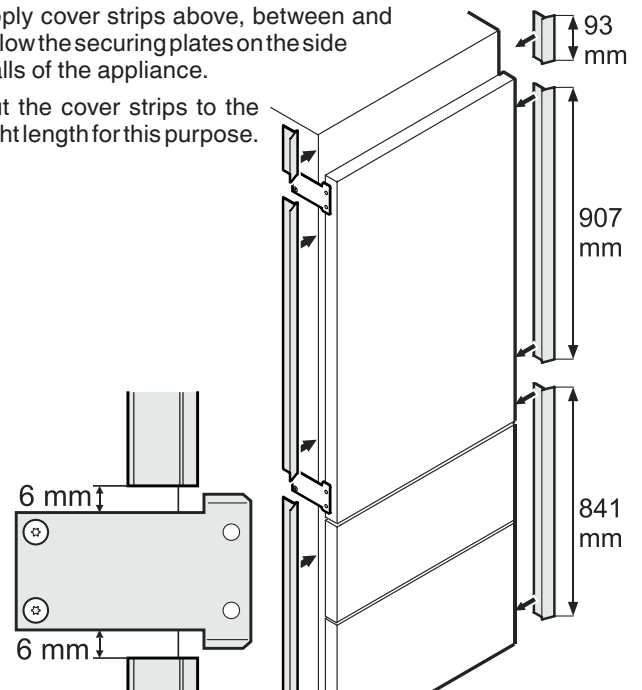

Apply the cover strips 6 mm from the securing plates.

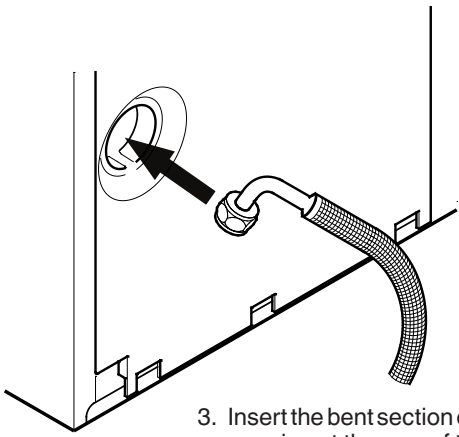

3. Insert the bent section of the hose through the opening at the rear of the appliance.

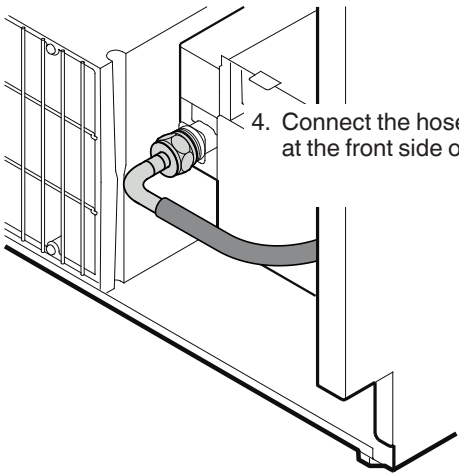

4. Connect the hose to the solenoid valve at the front side of the appliance.

- 5. Route the mains cable towards the socket.
- 6. Route the water hose towards the water shut-off valve.

WARNING!

Do not connect the appliance to the power supply until the installation is completed.

CAUTION!

Lay the mains cable and the water hose in such a way that they will not be damaged when the appliance is slid into the installation recess.

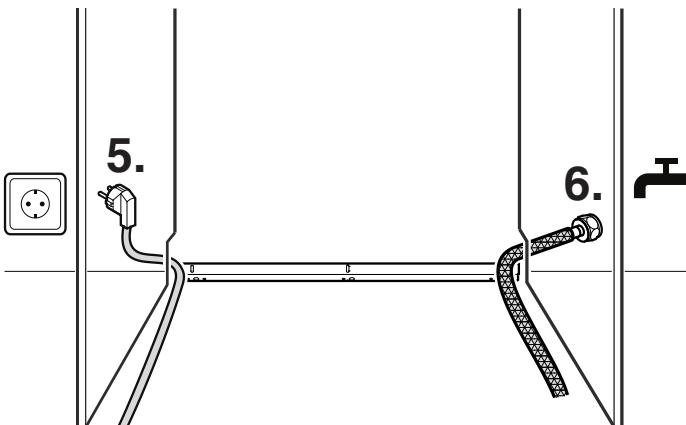

- 7. Push the appliance slowly into the recess until the compressor mounting plate touches the anti-tipping bracket.

WARNING!

To prevent the appliance from tipping forwards, the compressor mounting plate must be touching the anti-tipping bracket!

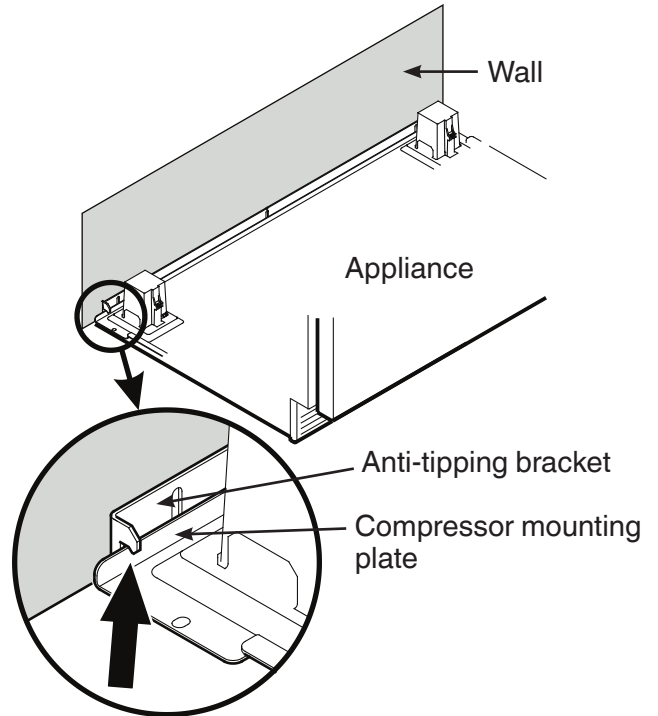

- 8. Connect the hose to the shut-off tap. Open the shut-off tap and check the system for leakage.

Important!

After the ice maker has been switched on, the water supply system must be bled. See the section **Bleeding the ice maker** in the operating instructions.

Levelling the appliance

1. Adjust the height of the appliance at the front by twisting the adjustable feet ① (A/F 27). Use the open-ended spanner provided.

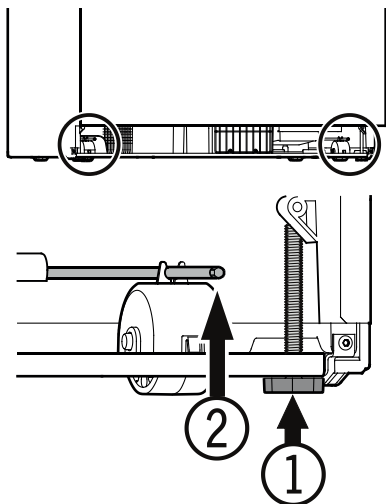

Caution!
The front feet of the appliance must be firmly placed on the floor.

2. Adjust the height of the appliance at the rear by turning the adjusting bars ②.

Turn the adjusting bars clockwise until the compressor mounting plate touches the anti-tipping bracket.

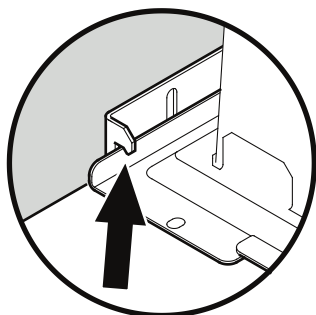

Adjusting the refrigerator door

The lateral tilt of the refrigerator door can be adjusted if required. Undo screws ①. Adjust the lateral tilt using the grub screw ② (Allen key A/F 2.5).

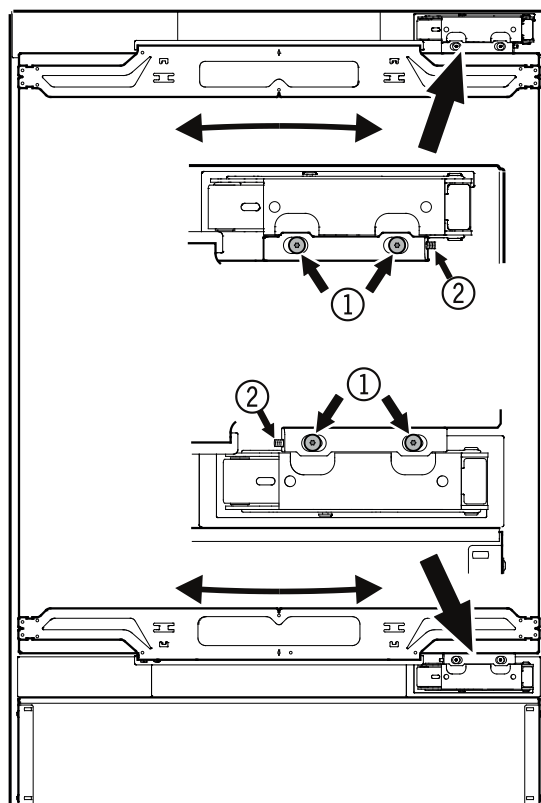

Fastening the appliance in the recess

Once in the recess, secure the appliance to the body of the unit using the securing plates (4 x 16 screws). Then click the covers supplied into place.

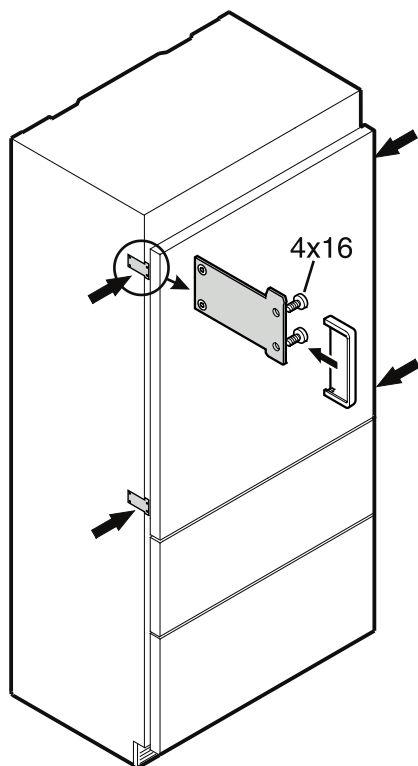

Adjusting the front of the drawer

If required, the front of the freezer drawers can be adjusted.

Transfer the screws shown in the illustration (on the left and right sides of the freezer drawer) individually to the long slots below.

Tighten the screws in the front of the drawer once it is in the right position.

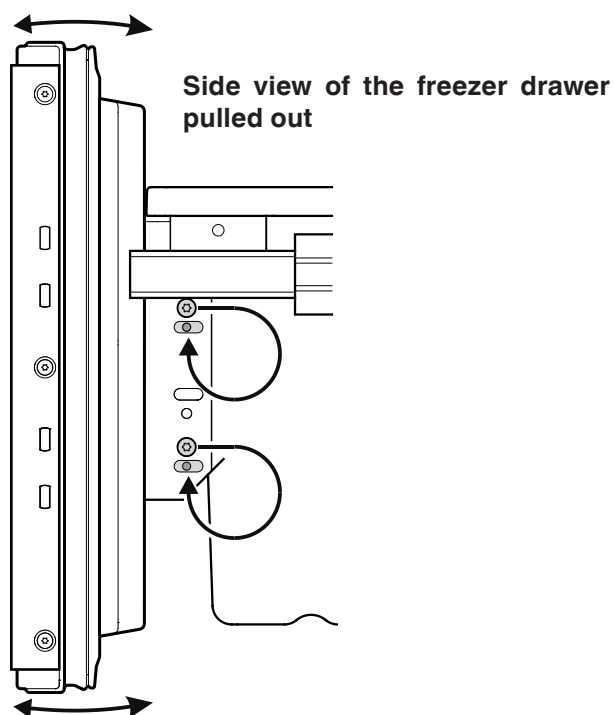

Before fitting the door panels

Remove the cover ① and unscrew the top and bottom attachment brackets ② from the refrigerator door. These attachment brackets will be mounted onto the refrigerator door panel.

Important!

The securing nuts are needed for re-mounting the pre-assembled door panel onto the refrigerator door.

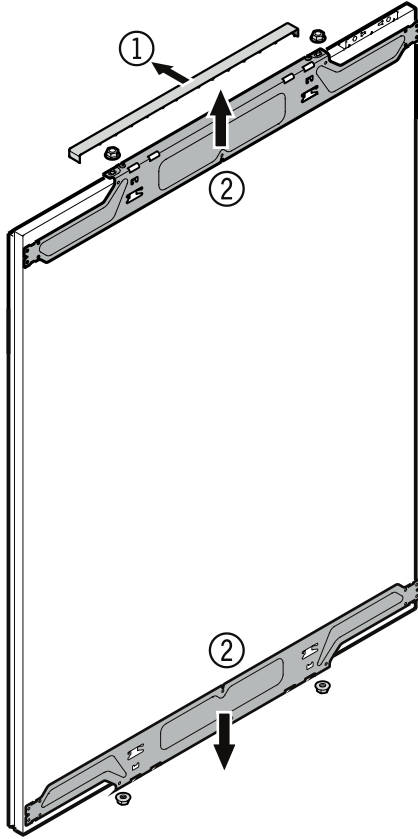

Unscrew the attachment brackets ③ from the freezer drawers. These attachment brackets will be mounted onto the freezer panels.

Important!

The screws are needed for re-mounting the pre-assembled freezer panels onto the freezer drawers.

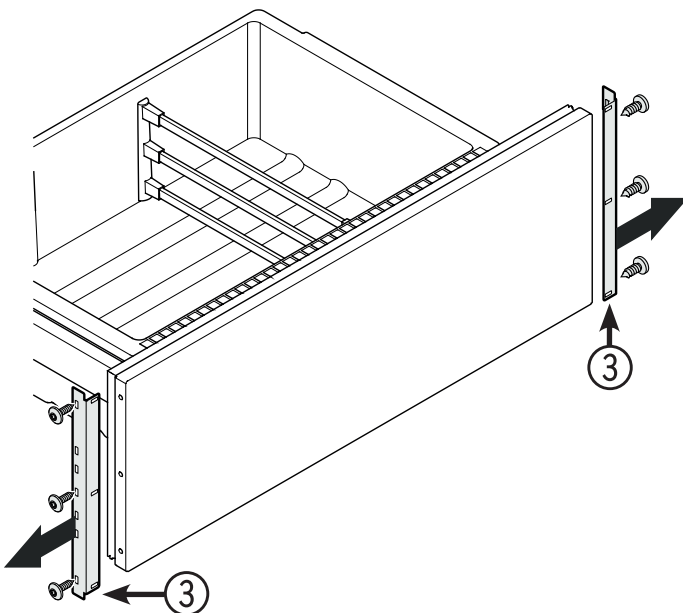

Panel dimensions

Min. panel thickness = 16 mm
Max. panel thickness = 19 mm

Maximum panel weight

Refrigerator panel = 27 kg
Freezer drawer panel = 10 kg

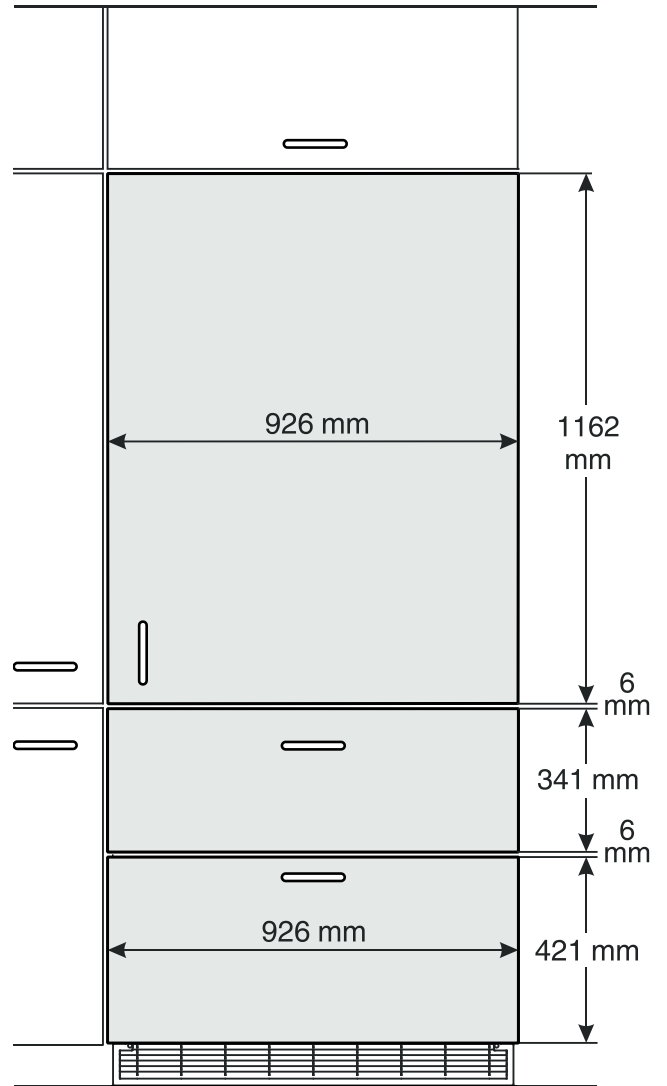

Mounting the attachment brackets onto the door panels

1. Draw a line 1041 mm from the bottom side of the door panel.
2. Draw a further line 107.5 mm from the bottom side of the door panel.
3. Align one of the refrigerator door attachment brackets to the top line, as shown in the illustration below, and secure with at least 6 4 x 14 screws.
4. Align the second refrigerator door attachment bracket to the bottom line, as shown in the illustration below, and secure with at least 6 4 x 14 screws.
5. Secure each of the attachment brackets that have been removed from the freezer drawers using 3 4 x 14 screws, as shown in the illustration below.

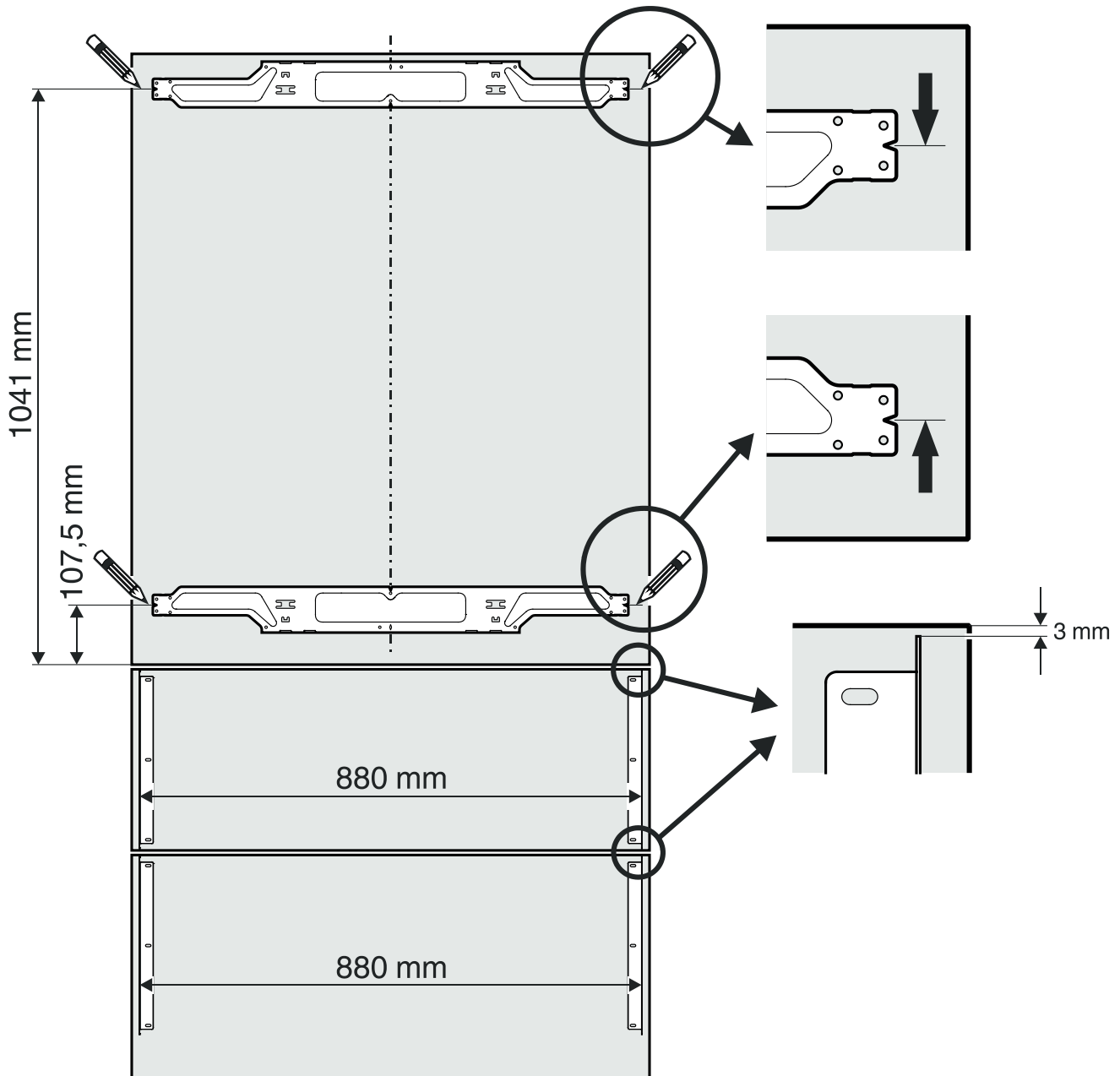

Mounting the refrigerator panel

1. Screw in the adjusting pins on the underside of the refrigerator door completely (**fig. A**).

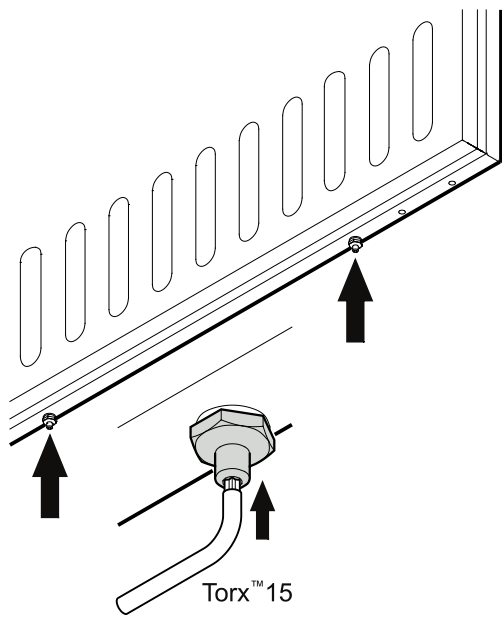

fig. A

2. Open the refrigerator door and suspend the refrigerator panel on the top adjusting pins (**fig. B**).
3. Screw securing nuts onto the adjusting pins and slightly tighten (**fig. B**).

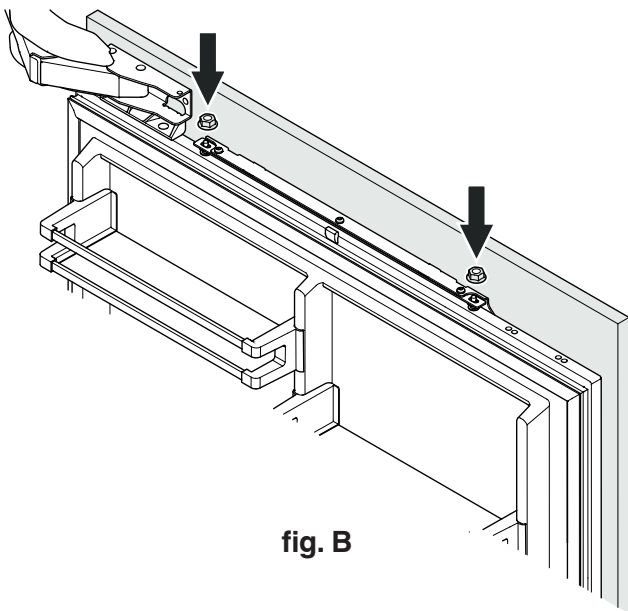

fig. B

4. Close the refrigerator door and check the height of the panel.
5. Adjust the height of the panel if necessary. Undo the securing nuts and use the adjusting pins to adjust (**fig. C**).

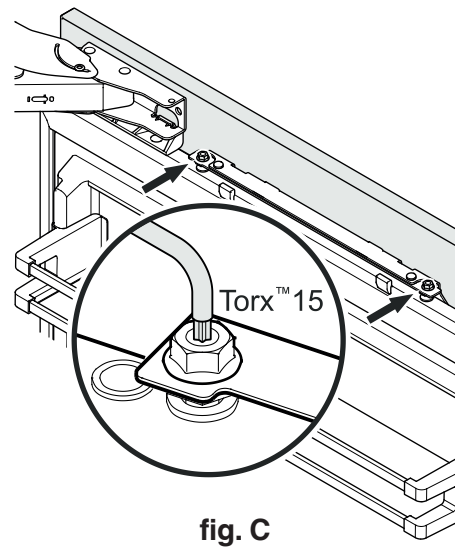

fig. C

6. Adjust the panel horizontally (using the long slots in the attachment bracket) (**fig. D**).
7. Tighten the securing nuts.

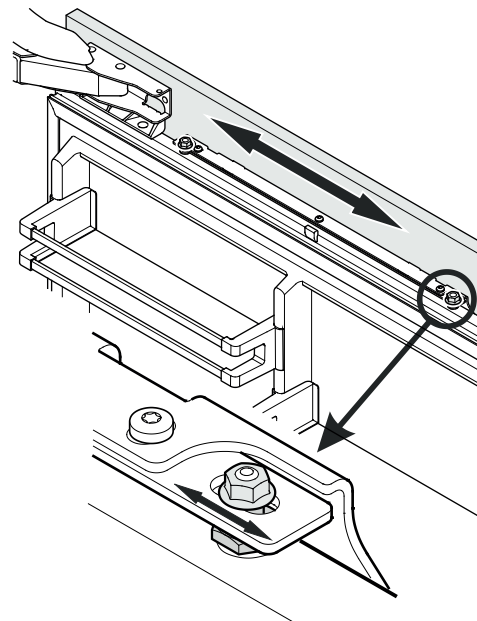

fig. D

8. Remove the adjusting pins (bottom of the refrigerator door) until these touch the attachment bracket (**fig. E**).

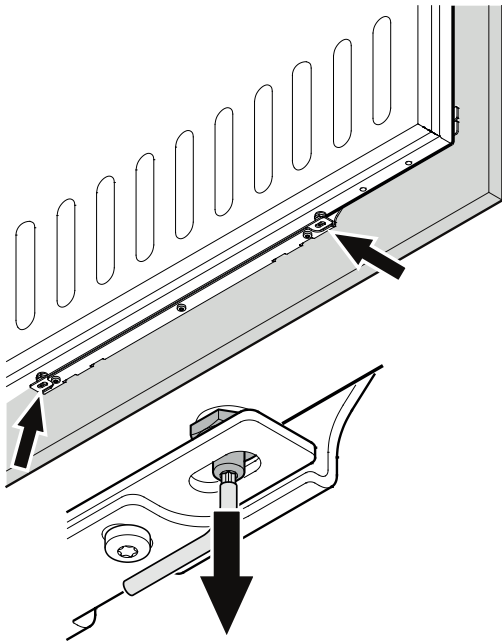

fig. E

9. Screw on the securing nuts and tighten (**fig. F**).

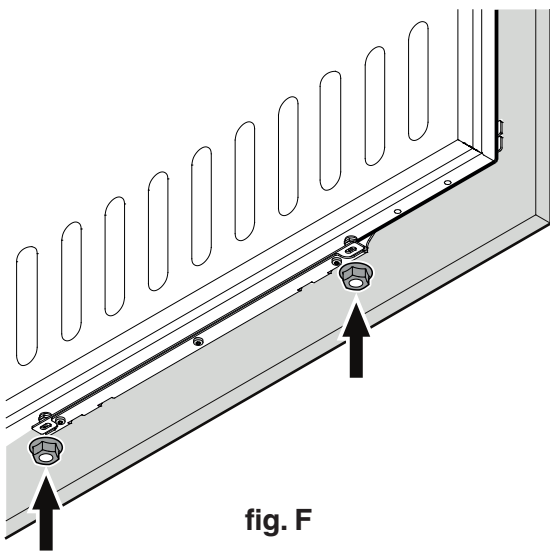

fig. F

10. Undo the three screws on the top of the attachment bracket, adjust the door panel as displayed in **fig. G** and then retighten the screws. The same procedure can be carried out for the bottom attachment bracket.

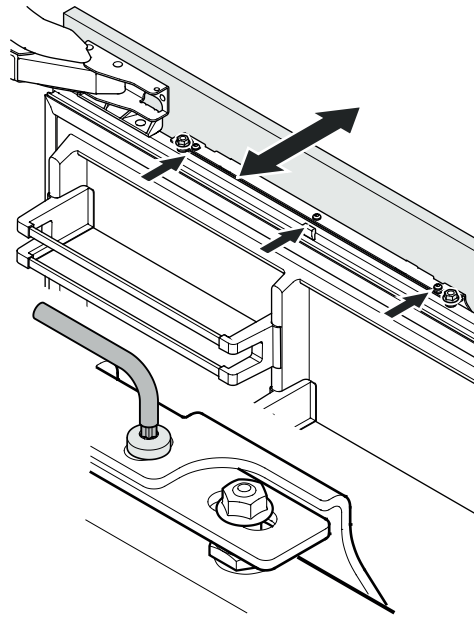

fig. G

11. Click the top and bottom covers ① into place (**fig. H**).
Insert the cover strip provided ② between refrigerator door and panel.

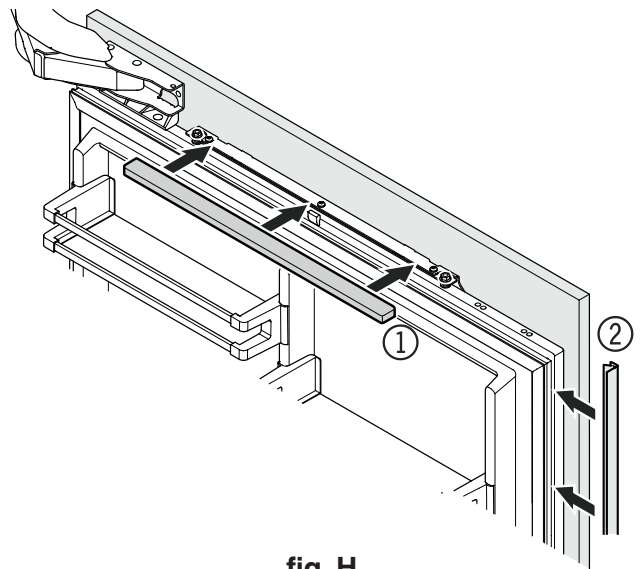
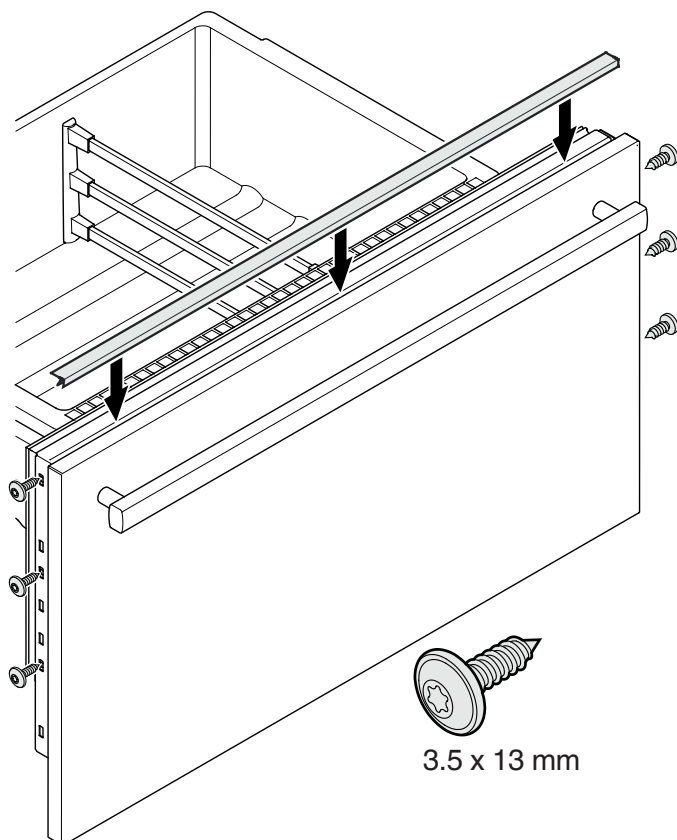

fig. H

Mounting the freezer panels

1. Pull out the top freezer drawer and screw on the pre-assembled panel. The same screws must be used as those used to screw on the attachment brackets (3.5 x 13).
2. Close the freezer drawer and check the position of the panel. Adjust the height of the panel by undoing the left and right screws. Tighten the screws.
3. Pull out the bottom freezer drawer and mount the panel in the same way.
4. For both drawers, cover the gap between the drawer and the panel with the cover strips supplied. Remove the protective film from the trim and insert into the gap at the top.



Mounting the dust filter

The supplied dust filter prevents that dirt enters the motor compartment, reducing the refrigeration performance. Therefore always install the dust filter.

1. Pull the bottom freezer drawer right out.
2. Remove the protective film from the dust filter. Insert the filter at the bottom, press the button down and click the filter into place.

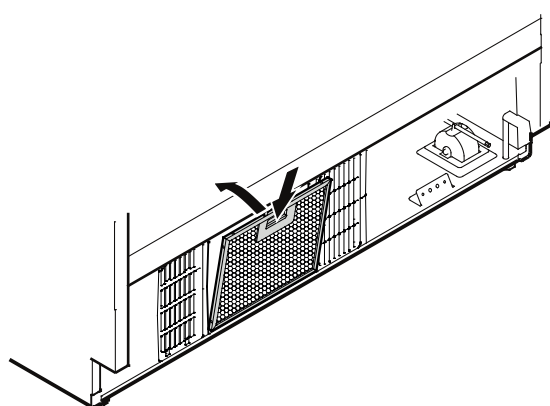

Mounting the ventilation grille

Important!
To ensure fault-free operation of the appliance, you must install the supplied ventilation grille.

Do not obstruct the ventilation opening or cover it with a panel!

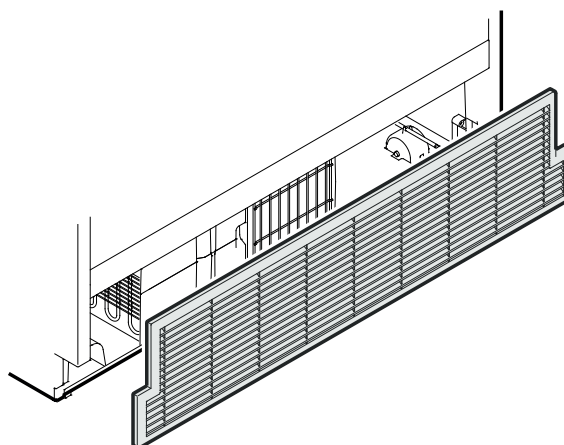

Changing over door hinges

Door hinges should only be changed by a trained expert.



WARNING!

Do not try to change over the door hinges yourself. The refrigerator door hinges are fitted with strong closing springs. If the hinge accidentally snaps shut, this can lead to serious injury.



Liebherr Hausgeräte Lienz GmbH

Dr.-Hans-Liebherr-Strasse 1

A-9900 Lienz

Österreich

www.liebherr.com

