

MOVE

Versiune

Incorporat 90 cm - Negru - 800 m³/h

Colectie

Design

Cod EAN

8034122352183



Fotografie cu caracter strict orientativ
Aceasta poate sa nu corespunda versiunii selectate

CARACTERISTICI

Inox AISI 304 Scotch Brite

Parte inferioara din sticla tratata termic culoare neagra

Usa glisanta

Control electronic

Filtru de grasime metalic, detasabil si lavabil

Optional - filtru combinat

Carbon.Zeo, regenerabil

Posibilitatea de a conecta la tubulatură prin partea din spate

Optional - masca pentru tubulatura

**Optional - raft de sticla
Dynamic LED Light (2700K - 5600K)**

Control: indicarea comenzilor pe panoul de comanda frontal (Panoul de comanda se afla in partea de sus)

ACCESORII OPTIONALE

KACL.934

Filtre Carbon.Zeo

KACL.815

Lavete pentru curatare inox (cutie 10 buc)

KACL.107

Sticla raft 90 cm

KCVJN.01#3

Masca pentru tubulatura h 120 mm

KCVJN.00#3

Masca telescopica pentru tubulatura h 185 + h 185

KACL.798#41F

Motor de acoperis 950 m³/h

KACL.770#41F

Motor de acoperis 1100 m³/h
Brushless

KACL.786#41F

Motor de exterior 1000 m³/h

CARACTERISTICI TEHNICE

AMBALARE: GREUTATE SI VOLUM

FISA TEHNICA MOTOR

Tip de instalare

Incorporata

Dimensiuni

90 cm

Finisaj

Inox Scotch Brite (AISI 304)

Parte inferioara din sticla tratata termic culoare neagra

Motor

800 m³/h

Tipul panoului de control

Control electronic

Setari de viteza

4

Iluminare

Led 3x1,2 W - 2700 K / 5600 K

Filtru

Filtru metalic "Base" - 198x161 mm - 2 pz

Filtru de Carbon

Filtre Carbon.Zeo

Distanta minima

Plita cu gaz: 52 cm

Plita electrica: 52 cm

Greutate bruta

20.20 kg

Greutate neta

16.80 kg

Volume

0.18 m³

Dimensiuni ambalaj

Lungime

995 mm

Inaltime

465 mm

Adancime

400 mm

CARACTERISTICI CONSUM SI CONEXIUNE

Consum maxim

280 W

Curent

220-240V

Frecventa

50-60Hz

Tip stecher

Shuko

Capacitate maxima

680 m³/h

I.E.C. 61591

Nivel de zgomot maxim

68 dB(A)re1pW

I.E.C.60704-2-13

Presiune maxima (Pa)

500 Pa

Putere maxima motor

215 W

CLASA DE ENERGIE

B

MOVE

Versiune

Incorporat 90 cm - Negru - 800 m³/h

Colectie

Design

Cod EAN

8034122352183

Optional shelf

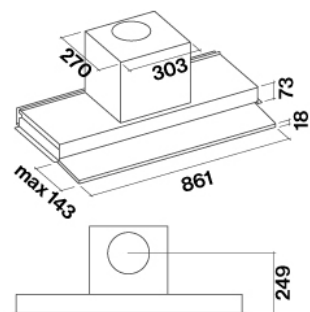

Optional chimney

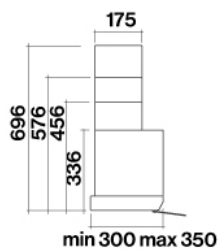

Optional shelf

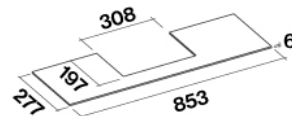

MOVE

Versiune

Incorporat 90 cm - Negru - 800
m³/h

Colectie

Design

Cod EAN

8034122352183

FISA TEHNICA MOTOR

Viteza motorului	1	2	3	4
Nivel de zgomot dB(A)re1pW-I.E.C.60704-2-13	49	56	62	68
Capacitate (m3/h) I.E.C.61591 Tubulatura	280	370	480	680
Presiune maxima (Pa)	390	420	480	500
Putere motor (W)	132	153	175	215
Evacuare aer	150	150	150	150

CAPACITATE/ PRESIUNE

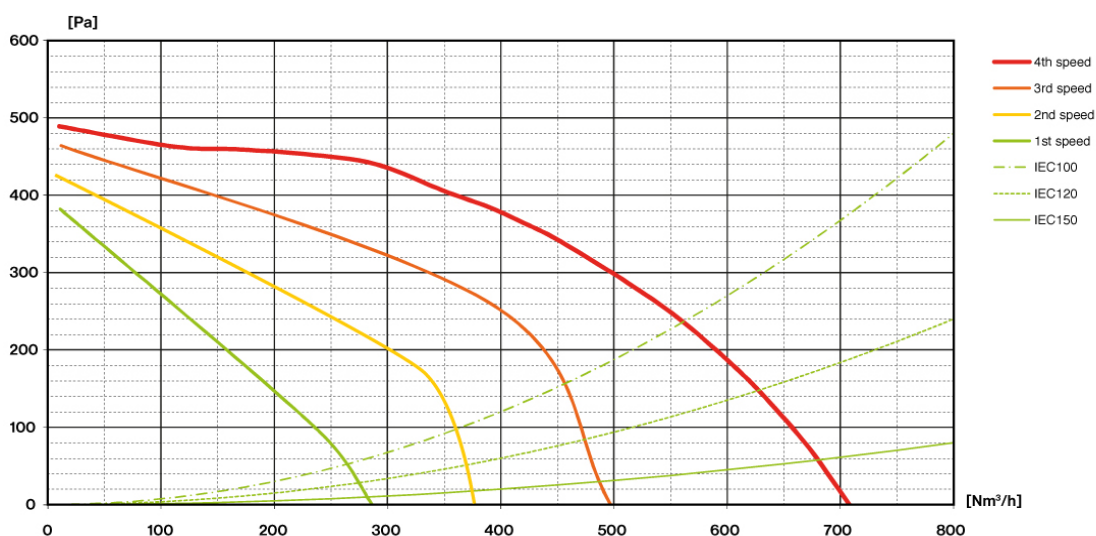

MOVE

Versiune

Incorporat 90 cm - Negru - 800 m³/h

Colectie

Design

Cod EAN

8034122352183

ETICHETA DE ENERGIE

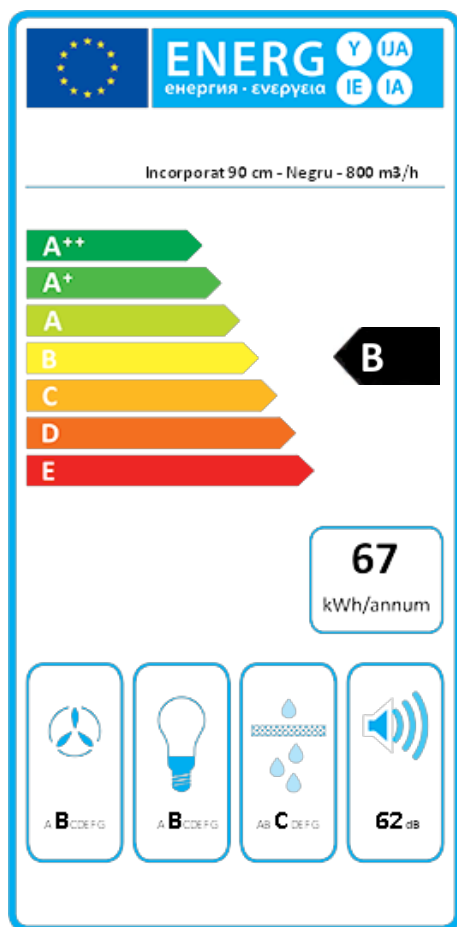

PF		
S	Falmec Spa	
M	Incorporat 90 cm - Negru - 800 m ³ /h	
AEC	67,0	kWh/a
ECC	B	
FDE	26,3	
FDEC	B	
LE	20,7	
LEC	B	
GFE	80,0	
GFEC	C	
Qmin	280,0	m ³ /h
Qmax	480,0	m ³ /h
Qboost	680,0	m ³ /h
SPEmin	49	dBa
SPEmax	62	dBa
SPEboost	68	dBa
PO	-	W
PS	0,48	W
PI		
F	1,1	
EEl	64,3	
Qbep	382,0	m ³ /h
Pbep	384	Pa
Qboost	680,0	m ³ /h
Wbep	155,1	W
WL	6,50	W
Emiddle	134	lex
Lwa-SPEmax	62	dBa